

# FMD88-10 PLC

FMD-series : Ethernet, Modbus TCP/IP, Stepper Motor Drive, +Analog I/O, LCD port, RS232, RS485, Internet-TRiLOGI Ladder+Basic

## Product Description

The FMD88-10 PLC is an upgrade version of the T100MD888 model, bringing its built-in capabilities very much in line with that of the super F-series PLCs. With the inclusion of an onboard Ethernet port, a faster CPU, more analog I/Os and program memory, the FMD88-10 provides great enhancement opportunities for applications currently using the T100MD888. However, if preferred, the FMD88-10 can also, in most cases, work simply as a drop-in replacement for the T100MD888 PLC.

Built into the FMD88-10 PLC are 8 digital inputs (includes 2 high speed encoders and 4 interrupts), 8 digital outputs (supports 4 PWM channels and 2 stepper motor pulse/direction controls) and 10 analog I/Os. Digital I/O capacity can be expanded to 120 digital inputs and 120 digital outputs using Triangle Research expansion boards EXP1616R or EXP4040. Analog I/O expansion modules which connect to the FMD88-10's RS485 port are also readily available. Like all 'super' PLCs in Triangle Research's line-up, the FMD88-10 is designed with ready connectivity to many peripheral device types. With the built-in Ethernet port and the iTRiLOGI client/server software, the FMD88-10 is fully accessible for machine monitoring and OEM troubleshooting/reprogramming over the INTERNET. Built-in RS232 and RS485 connections and support of MODBUS protocols also makes the FMD88-10 easy to integrate into mixed-brand PLC environments and networks.

As for all the super PLCs from Triangle Research, programming of the FMD88-10 PLC is simplified with the powerful iTRiLOGI Ladder+BASiC software that is shipped with the starter kit. Similarly, as for all Triangle Research PLCs, the FMD88-10 PLC incorporates a program code security feature in the interest of Automation OEMs' program protection.

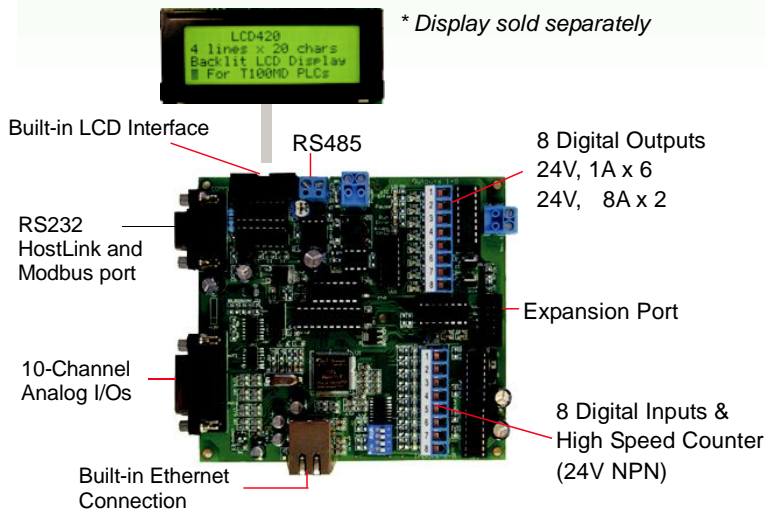

## Mounting

(a) Hole Mounting Locations for direct panel mount.

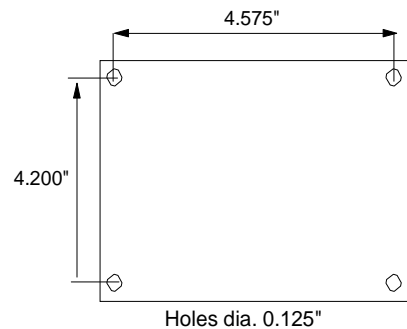

(b) Optional DIN-rail mounting kit available for installation on din rails.

## Accessories

- LCD Displays : LCD216 (2 lines x 16 char.), LCD420 (4 lines x 20 char.)
- Networked Display : MDS100-BW for multiple displays application or for extended mounting of display
- MD-HMI : 16-key pad with 8 LED and 4x20 LCD; plugs into LCD and expansion ports
- MMI6050 : 4.3' Color Graphics Touch Panel HMI
- I/O Expansion : Exp4040 or Exp1616R (16 Opto-isolated Digital Inputs, 16 Relay Outputs)
- FRAM RTC : Battery-Backed Real Time Clock plus Program/Data Memory Expansion
- Auto485 : RS232 to RS485 converter
- Analog Expansion : I-7000 series Analog I/O Expansion Modules
- USB-RS232 Interface : for connection to USB port on PC
- Din Rail Mounting : Din-Kit-2

Operating Voltage	12 to 24V DC (+/- 5%)	
Digital Inputs	8 (24V npn) with LED indicators	
	Encoder Inputs	- 2 x 32-bit High Speed Counter (quadrature: 2 D/Is per channel)
	Interrupts	- 4 x user-defined interrupt (latency < 0.5ms, +ve or -ve edge triggered)
Digital Outputs	8 (24V npn) with LED Indicators	
	#1 to #6 : 24V, Max 1A npn, Continuous Output Current 250mA, Driver Type : NPN Darlington Transistor	
	#7 to #8 : 24V, Max 8A npn, Continuous Output Current 4A, Driver Type : N-Channel power MOSFET with low r <sub>DS</sub> = 0.05 Ω	
	PWM (current)	- 4 x PWM; shares with D/O #5 to #8 (continuous frequencies, 0.1% duty cycle resolution)
	Stepper Motor Control	- 2 x stepper motor control pulse/direction outputs (2 D/Os per stepper output)
Analog I/O	10	
	- Input Interface	8 x AI -12 bit, 0-5V
	- Output Interface	2 x AO - 12 bit, 0-5V or 0-10V (Software selectable!). Expandable to 4 channels (0-5V)
Processing	I/O Scan time = 1ms (can be interrupted by input interrupts), Program Scan time = 4µs per step	
High-Speed Counter	2x high-speed counters, 4x pulse measurement channels (frequency, period and width) - simultaneous position and speed measurement on each channel.	
Counters	64	
Internal Relays / Timers	512 internal relays, 64 timers (any one or all can be configured as "HighSpeed" timers)	
Sequencers	8 with 32 steps (step# 0 - # 31)	
Real-Time Clock	Standard : Real Time Clock and Calendar (Year, Day, Month, Hours, Min, Sec, day-of-week) - no battery backup	
	With FRAM-RTC : Real Time Clock and Calendar (Year, Day, Month, Hours, Min, Sec, day-of-week) - battery backup	
PID	Built-in 16 channels PID Computation function (Proportional, Integral, Derviative digital control)	
Connection Ports	- RS232	1 x (DB9 Female Socket)
	- RS485	1 x (two-pin screw terminals)
	- Ethernet	1 x RJ45
	- Analog I/Os	1 x DB-15 female socket for Analog Inputs and Outputs
	- LCD	1 (IDC 14-pin)
	- Others	2 x 8 way detachable screw terminals (5mm pitch) for digital inputs and outputs
Communications	Ethernet	- Direct connection to LAN or Internet for programming, monitoring and Remote Control - Support both Modbus/TCP Server (5 simult. connections ) and Modbus/TCP Client - Extremely easy Peer-to-peer (or machine-to-machine) PLC communication. - TCP connection to any Server IP address:port number (e.g. to NIST Timer Server) - Event-driven Emailing. Create and save data file on a networked PC's hard disk - Excel spreadsheet Data Logging using TRI-ExcelLink software - Supports web query. Enterprise Database or MS Excel software can log PLC data directly via the Internet.
	RS232 & RS485	Supported Protocols : Native ASCII Host Link Commands (programming/monitoring) MODBUS RTU, MODBUS ASCII, OMRON C20H Host Link Commands Default COM speed 38,400 bps, may be set from 1200 to 115.2K & 230.4K bps
Memory Storage	Standard	
	- Program	8K words (16-bit) of program memory stored in flash memory.
	- Data	A to Z (32-bit Integer), A\$ to Z\$ (ASCII strings) DM[1] to DM[1000] (16-bit integer array) 1K Words (16-bit) additional non-volatile Flash memory for integer and string storage
	With FRAM-RTC	
- Program	16K words (16-bit) of program memory stored in flash memory.	
- Data	A to Z (32-bit Integer), A\$ to Z\$ (ASCII strings) DM[1] to DM[4000] (16-bit integer array) - configurable to non-volatile. 11K Words (16-bit) non-volatile Ferromagnetic RAM memory for integer and string storage.	
Programming Lang. / Env.	iTRiLOGI Version 6.xx (Ladder+Basic) / Windows	
Dimensions / Weight	4.825"(L) x 4.45"(W) x 0.8"(H) / 4.9 oz (140 gms)	
I/O Expansion (Digital)	Expandable to 120 D/I and 120 D/O using EXP4040 and EXP1616R.	
I2C Interface (Future)	Optional I2C-FRTC module provides I2C interface and 256K bytes EEPROM. (To Be Announced)	

PLC Environmental Specs (Temperature and Vibration)

Operating Temperature	- Operating 0 to 70 deg C (32 to 158 deg F) - Storage -20 to +85 deg C (-4 to 185 deg F)
Operating Humidity	10% - 90% Rel. Humidity, non condensing
Electrical Noise Resistance	IEC801-4 (Fast transient) - 2KV to power supply, 50 microsecond pulse width, 1 min. 1KV to I/O by capacitive coupling, 50 microsecond pulse width.
Vibration resistance	IEC 68-2-6/1980 Vibration 1.6mm - 25Hz to 100Hz - Amplitude = +1. - Acceleration = + 4.0g

Absolute Max. Rating

Power Supply Input	30V
Digital Inputs	30V
Digital Outputs	30V
Relay Outputs	30VDC/250VAC
Analog Channels (0 to 5V)	7V