

Nano-10 PLC

Nano: Ethernet, Modbus TCP/IP, RS485, +A/I, Internet-TRiLOGI Ladder+Basic

Product Description

The Nano-10 has only 10 I/Os, but is a full-function programmable logic controller with many of the features found only in bigger and much more expensive PLCs. Measuring only 3.3" by 2.8" and weighing in at 2.6 oz, this nano class controller packs a big punch and stands out with its built-in Ethernet port which supports MODBUS TCP/IP Server and Client connections. In addition, an RS485 connection which supports native host link commands protocol as well as MODBUS RTU and MODBUS ASCII, makes it possible not only to communicate with other Triangle Research PLCs, but also other makes of PLCs and a whole range of other devices that support the same industry standards.

Designed to be internet-savvy, the Nano-10 allows machine OEMs and integrators to easily create a web page that allows them to control their equipment remotely without having to write a single line of Internet program. This is cleverly done by simply defining a background image and modifying a few variables that define the I/O labels and their locations on a browser screen.

Programming of the Nano-10 is done using the highly acclaimed and very efficient iTrilogi "Ladder+BASIC" language. The PLC has 4 digital inputs which support high speed counter and interrupt functions. The 4 digital outputs (2 of which are voltage-free relays) are capable of supplying 2 channels of PWM current, or of controlling pulse and direction for a stepper motor. Other features of this PLC include a fast CPU processing speed of 4 μ s per step, counters/internal relays/sequencers, PID computation engine and real time clock (an optional FRAM-RTC module provides non-volatile Ferromagnetic RAM memory for data storage and a battery-backup Real-Time Clock).

The low price of the Nano-10 brings a whole new level of PLC sophistication to smaller and lower end automated machines. The Nano-10 is ideal in applications which require a small I/O count but which have the same demand for capabilities and networking as larger and more complex systems.

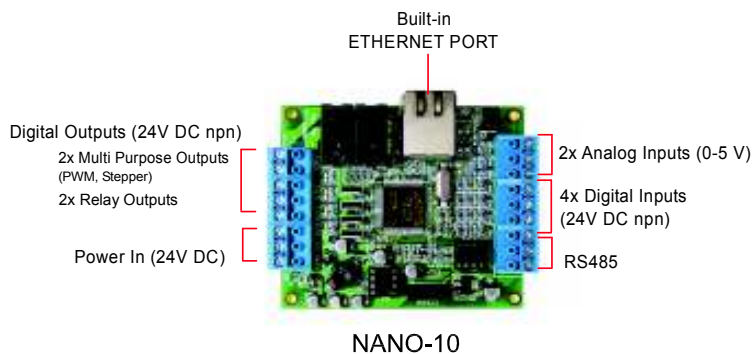

Mounting

(a) Hole mounting positions for direct panel mount

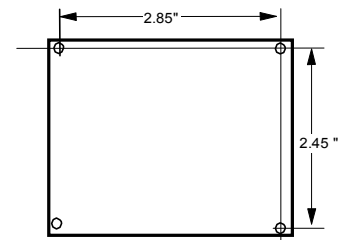

(b) Optional Din-Rail mounting kit available

Special Nano-10 Feature

Quick Setup User PLC Control Web Page

The Nano-10 PLC allows users to easily create their own savvy web page for remote interaction with the controlled equipment without the need to write any Internet program. A user is only required to define a background image and modify relevant variables that define the I/O labels and their locations on a browser screen for a quick set-up his/her own custom-made control web page.



Accessories

- FRAM-RTC Battery-Backed Real Time Clock plus Program/Data Memory Expansion
- Auto485 Converter between RS485 and RS232
- Networked Display : MDS100-BW for multiple displays application or for extended mounting of display
- U-485 : for RS485 connection to USB port on PC
- Din Rail Mounting : Din-Kit-1B

Features and Specs

Nano PLC

Operating Voltage	Input 24V DC (+/- 5%)	
Digital Inputs	4 (24V npn) with LED indicators	
	Encoder Inputs	- 2 x 32-bit High Speed Counter (quadrature: 2 D/Is per channel)
	Interrupts	- 4 x user-defined interrupt (latency < 0.5ms, +ve or -ve edge triggered)
Digital Outputs	4 (24V npn) with LED Indicators	
	#1 to #2 : 24V, Max 8A npn, Continuous Output Current 4A, Driver Type : N-Channel power MOSFET with low $t_{BS} = 0.05 \Omega$	
	#3 to #4 : Voltage-free RELAYS. Contact current = 5A @30VDC/120VAC or 2A @230VAC	
	PWM (current)	- 2 x PWM 8A @24VDC (continuous frequencies, 0.1% duty cycle resolution)
	Stepper Motor Control	- 1 x stepper motor control pulse/direction outputs (2 D/Os per stepper output)
Analog I/O	2	
	- Input Interface	2 x AI -12 bit, 0-5V
	- Output Interface	none
Processing	I/O Scan time = 0.5ms (can be interrupted by input interrupts), Program Scan time = 4µs per step	
High-Speed Counter	2x high-speed counters, 4x pulse measurement channels (frequency, period and width) - simultaneous position and speed measurement on each channel.	
Counters	64	
Internal Relays / Timers	512 internal relays, 64 timers (any one or all can be configured as "HighSpeed" timers)	
Sequencers	8 with 32 steps (step# 0 - # 31)	
Real-Time Clock	<u>Standard</u> : Real Time Clock and Calendar (Year, Day, Month, Hours, Min, Sec, day-of-week) - no battery backup	
	<u>With FRAM-RTC</u> : Real Time Clock and Calendar (Year, Day, Month, Hours, Min, Sec, day-of-week) - battery backup	
PID	Built-in 16 channels PID Computation function (Proportional, Integral, Derivative digital control)	
Connection Ports	- RS485	1 x (two-pin screw terminals)
	- Ethernet	1 RJ45
	- Others	1 x 8 way detachable screw terminals (5mm pitch) for power and digital outputs
		1 x 9 way detachable screw terminals for digital Inputs, analog inputs and RS485 port.
Communications	Ethernet	<ul style="list-style-type: none"> - Direct connection to LAN or Internet for programming, monitoring and Remote Control - Support both Modbus/TCP Server (5 simult. connections) and Modbus/TCP Client - Extremely easy Peer-to-peer (or machine-to-machine) PLC communication. - TCP connection to any Server IP address:port number (e.g. to NIST Timer Server) - Event-driven Emailing. Create and save data file on a networked PC's hard disk - Excel spreadsheet Data Logging using TRi-ExcelLink software - Supports web query. Enterprise Database or MS Excel software can log PLC data directly via the Internet.
	RS485	Supported Protocols : Native ASCII Host Link Commands (programming/monitoring) MODBUS RTU, MODBUS ASCII, OMRON C20H Host Link Commands Default COM speed 38,400 bps, may be set from 1200 to 115.2K & 230.4K bps
Memory Storage	<u>Standard</u>	
	- Program	8K words (16-bit) of program memory stored in flash memory.
	- Data	A to Z (32-bit Integer), A\$ to Z\$ (ASCII strings) DM[1] to DM[1000] (16-bit integer array) 1K Words (16-bit) additional non-volatile Flash memory for integer and string storage
	<u>With FRAM-RTC</u>	
- Program	16K words (16-bit) of program memory stored in flash memory.	
- Data	A to Z (32-bit Integer), A\$ to Z\$ (ASCII strings) DM[1] to DM[4000] (16-bit integer array) - configurable to non-volatile. 11K Words (16-bit) non-volatile Ferromagnetic RAM memory for integer and string storage.	
Programming Lang. / Env.	iTRiLOGI Version 6.xx (Ladder+Basic) / Windows	
Dimensions / Weight	3.34"(L)x 2.84"(W) x 0.75"(H) / 2.6 oz (76 gms)	
I/O Expansion (Digital)	NO direct I/O expansion. Remote I/O may be controlled via RS485 or Ethernet port.	

PLC Environmental Specs (Temperature and Vibration)

Operating Temperature	- Operating 0 to 70 deg C (32 to 158 deg F) - Storage -20 to +85 deg C (-4 to 185 deg F)
Operating Humidity	10% - 90% Rel. Humidity, non condensing
Electrical Noise Resistance	IEC801-4 (Fast transient) - 2KV to power supply, 50 microsecond pulse width, 1 min. 1KV to I/O by capacitive coupling, 50 microsecond pulse width.
Vibration resistance	IEC 68-2-6/1980 Vibration 1.6mm - 25Hz to 100Hz - Amplitude = +1. - Acceleration = + 4.0g

Absolute Max. Rating

Power Supply Input	30V
Digital Inputs	30V
Digital Outputs	30V
Relay Outputs	30VDC/250VAC
Analog Channels (0 to 5V)	7V