

T22H-NPN Installation Guide

The light weight and ultra small T22H-npn controller can be easily installed in many plastic or metal enclosures. You need to use 4 PCB standoffs to support the controller and to fasten it to a console box. Screw terminals are provided for quick connection to all input and output wires. In addition, each block of screw terminals can easily be detached from the controller body, enabling easy replacement of the controller board when necessary. The following sections describe various subsystems of the controller.

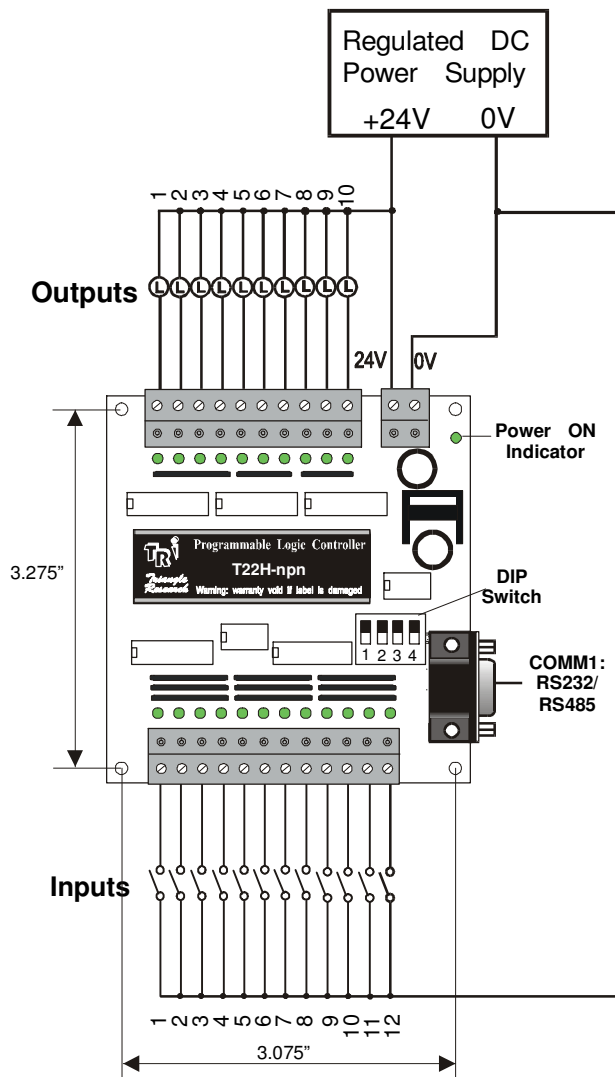
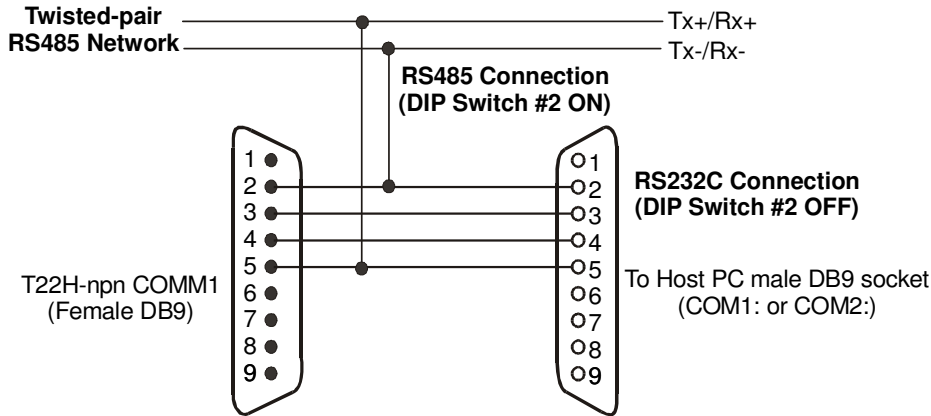

Figure 1 - Wiring diagram for T22H-npn

5. Host computer connection

Each T22H PLC has a built-in RS232/RS485 interface available on a single DB9 female socket as shown in Figure 1. This allows T22H-npn to be programmed by a host PC either locally by RS232 or remotely via an RS485 network using Network TRiLOGI. A T22H-npn may also be used as a remote I/O card for the T100MD or T100MX PLC.



The two-wire RS485 signals are available at PIN #2 (Tx-/Rx-) and PIN #5 (Tx+/Rx+) of the DB9 connector. DIP Switch #2 selects whether the communication is for RS232 or RS485 interface. (See next section for details). Programming of the T22H controller is done entirely on a PC and the program is subsequently downloaded to the controller via the host computer serial port. A simple straight DB9 cable is all that is needed for interfacing the host computer RS232C signal to the T22H PLC.

6. DIP Switch Settings

A 4-position DIP switch is situated just below the T22H CPU on the controller. The switches allow the controller to be configured for different operating modes, as indicated in the following table.

DIP SW	OFF	ON
SW1-1	All outputs, relays, timers and counter values are non-retentive.	The first 32 relays, timers #1-8 and counters #1-8 retain their logic status and present values when power off.
SW1-2	Select RS232 Interface	Select RS485 Interface
SW1-3	Baud Rate always = 9600	Use baud rate set by "BW" command (See User's Manual)
SW1-4	Normal Run mode	Suspends execution of ladder logic program. However, host communication remains active

1. System Resources

Internal Resources	Standard Type	T22H-plus NPN (CPU option)
Inputs	12	12
Outputs	10	10
Internal Relays	128	256
Timers	20	40
Counters	20	40
Sequencer	8	8
Maximum Program Steps	400	800

2. Power Supply

For normal operations the T22H-npn controller requires a single +24V (± 15%) DC regulated supply connected to the upper-right screw terminal block as shown in Figure 1. Although the PLC may still operate at power supply voltage as low as 12V DC, the power-failure retentive relay feature (enabled when DIP switch #1 is ON) will not work for power supply voltage below 18V.

You should use only industrial grade switching or linear regulated power supply from established manufacturers for best results. Using a poorly-made power supply can give rise to problems if the output voltage of the supply fluctuates widely when the load is turned ON/OFF. If the AC main is affected by nearby machines drawing large currents (such as large three-phase motors), use a surge-suppressor to prevent any unwanted noise voltage from being coupled into the T22H-npn's power supply.

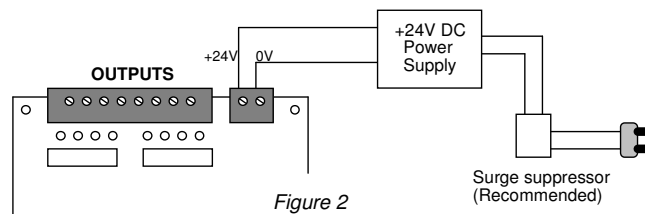

The T22H PLC consumes only about 0.1A of current when all its inputs/outputs are off, and each LED indicator on the input and output consumes only about 5mA. Thus the required current rating for the power supply depends mainly on the total average **load** current, taking into consideration the peak current demand and duty cycle of the operation. Normally, a 24V, 2A DC power supply is quite sufficient for most of the T22H applications.

3. Input Units

The T22H-npn's inputs are numbered from 1 to 12. These numbers correspond directly to the first 12 entries in TRiLOGI's Input Table.

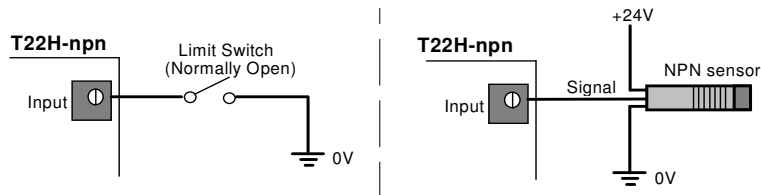

Input = logic '1' when Limit Switch is closed

Input = logic '1' when object is sensed

- Input Voltage for Logic 0 : Open Circuit or 8.5V to +30V DC
- Input Voltage for Logic 1 : 0V to +3.5V
- Input On delay : less than 0.1µs

4. Output Units

A T22H-npn controller provides 10 high-current transistor output points.

- Output Driver type : NPN Darlington transistors, sink up to 1.0A peak.
- Output Voltage when OFF : Pulled to +24V via 5.6K resistor and LED.
- Output Voltage when ON : 1.2V @ $I_{out} = 500mA$
- Inductive Kick Protection: : Built-in diode internally connected to the +24V supply to bypass inductive noise current.

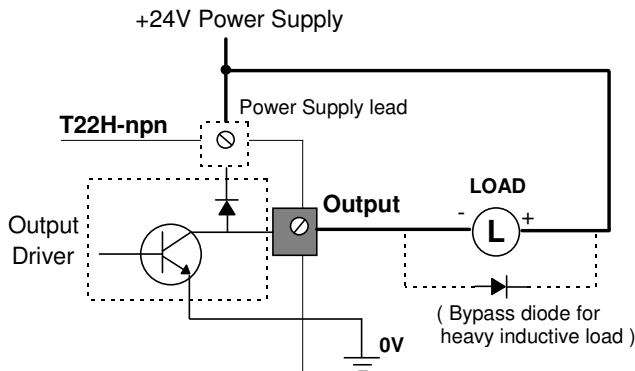

Note: When driving heavy inductive load which are situated far away from the controller, it may be necessary to connect external bypass diode across the load to suppress inductive noise, as shown in the above diagram.

Current Rating

Each transistor output terminal is capable of sinking (NPN type) up to 1.0A of peak current. Each output driver IC (ULN2003A) controls three and a half outputs. Without using a heat sink, every driver IC is capable of driving a continuous total current of 1.0A. For reliable operation, ensure that the sum of continuous current drawn by the 3 output-points to a driver does not exceed 1.0A in total. Use an intermediate relay with 24VDC coil if the load demands continuous high current exceeding 0.5A.